

4

3

2

1

Parts List

ITEM	QTY	PART NUMBER	DESCRIPTION
1	4	37030	1/2 Std NC Nylock Nut
2	4	37036	5/8 Std NC Nylock Nut
3	4	AMP-13211	1/2-13 x 2 HEX HEAD BOLT
4	4	AMP-13313	5/8-11 x 2 1/2 HEX HEAD BOLT
5	8	AMP-33012	1 3/8 x 9/16 x .118 Thk Steel Plain Washer
6	8	AMP-33016	1 3/4 x 11/16 x 1/8 Thk Steel Plain Washer
7	4	AMP-58212	2" DIA. DOUGHNUT, 1/2" NEOPRENE RUBBER
8	4	ASK-205-RA	.25 HRPO MOUNTING ANGLE

PARTS SHIPPED LOOSE

B

B

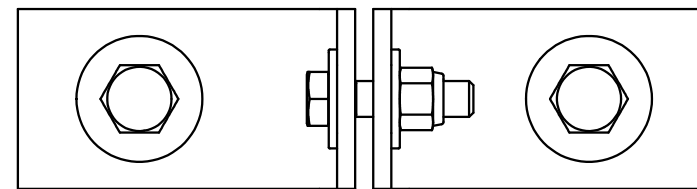
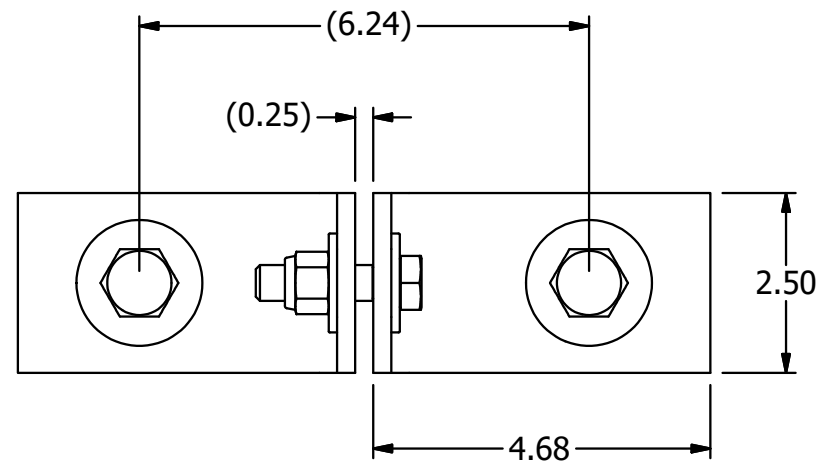

A

A

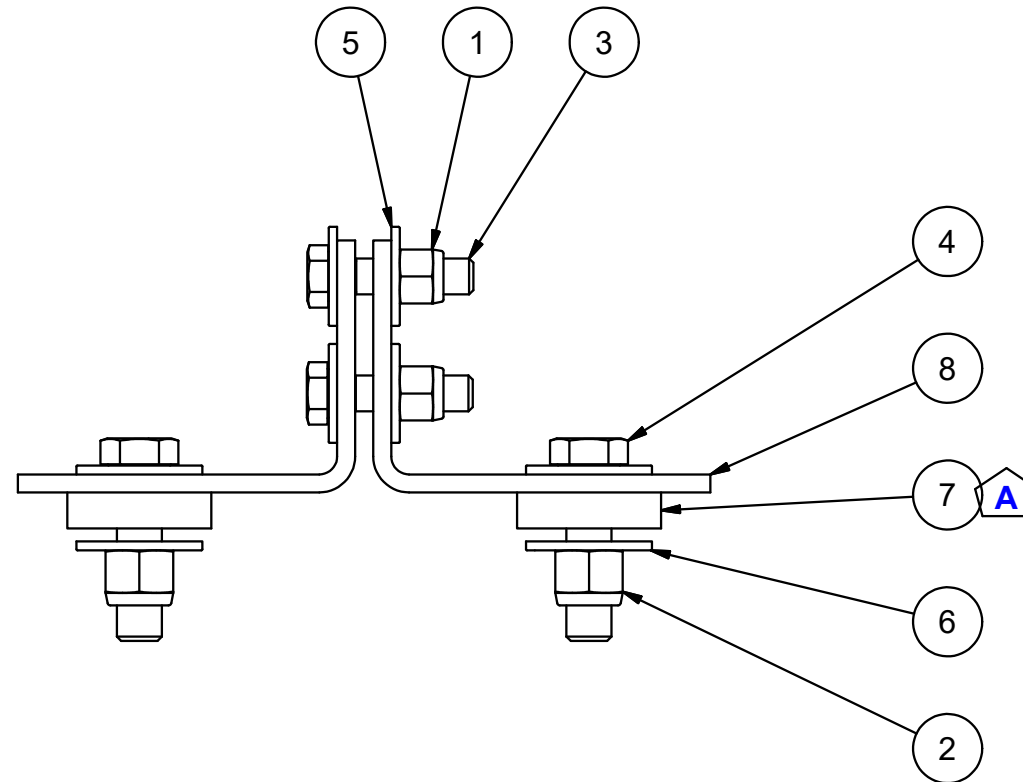
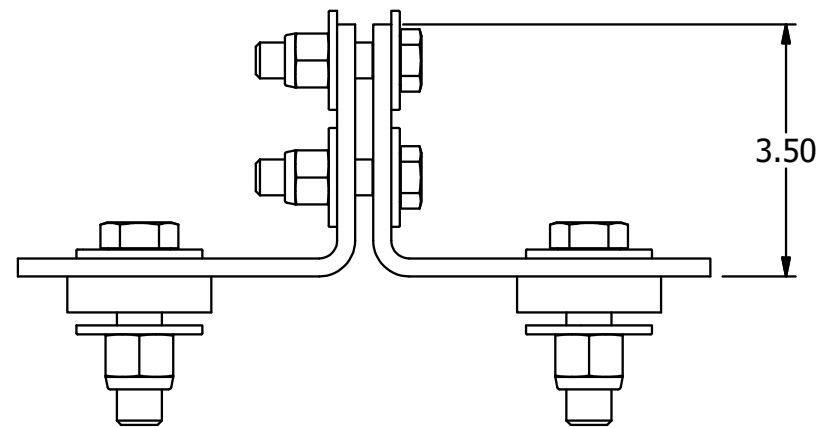

DATE	SYM.	DESCRIPTION	BY
10-24-18	A	PART NUMBER WAS ASK-200PAD	BPK

REVISIONS

AMERICAN MOBILE POWER PH: (800) 634-8265 FAX: (765) 948-3403	DRAWING BY: bknight	DESIGN FOR: AMP	FILE NAME: ASK-205-R	
	COMPLETED: 1/24/2008		SHEET: 1 of 2	SHEET SIZE: B

4

3

2

1

4

3

2

1

Parts List

ITEM	QTY	PART NUMBER	DESCRIPTION
1	1	ASK-205-RA	.25 HRPO MOUNTING ANGLE

FABRICATION PROCESS:

- BAND SAW CUT
- PRESS PUNCH
- PRESS BREAK

B

B

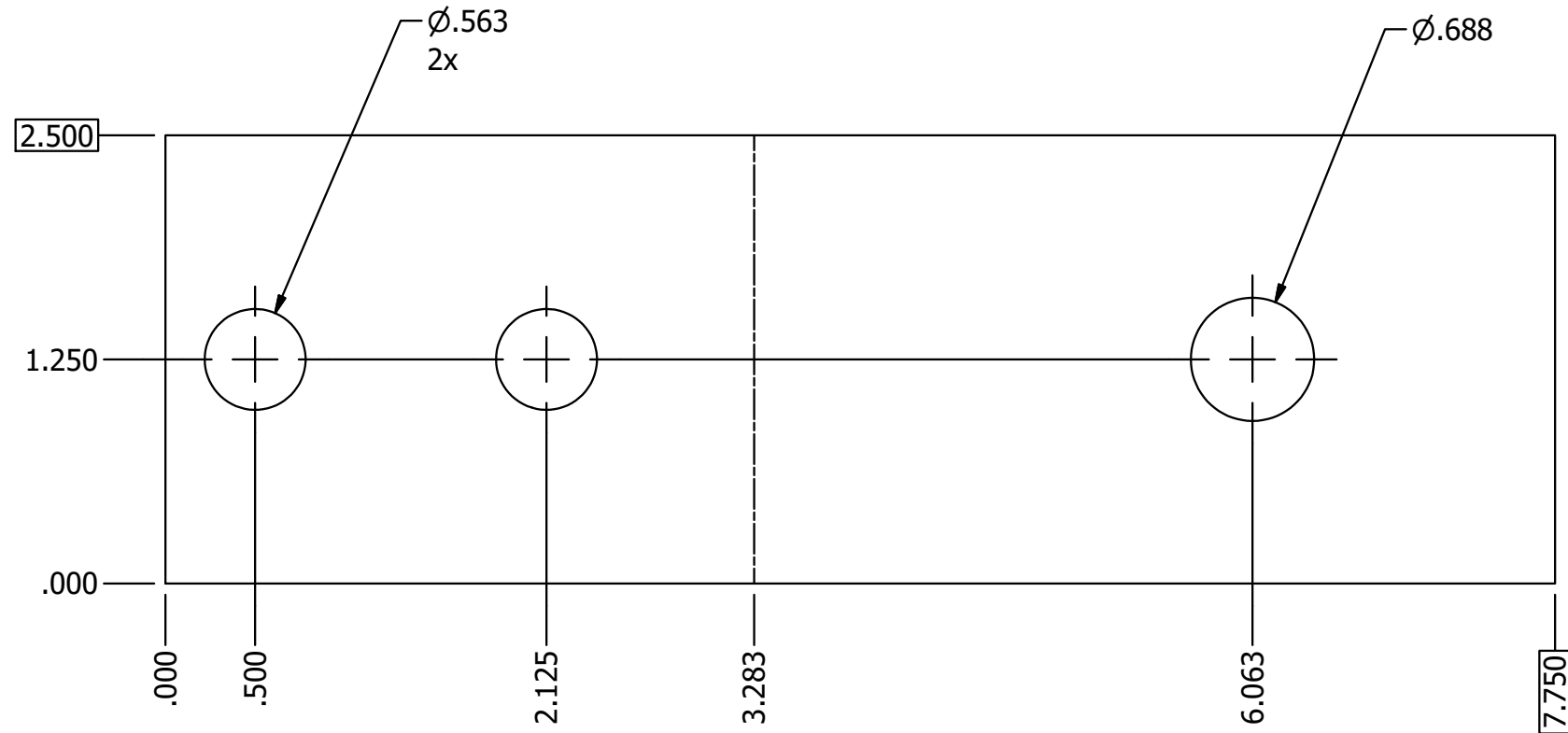

A

A

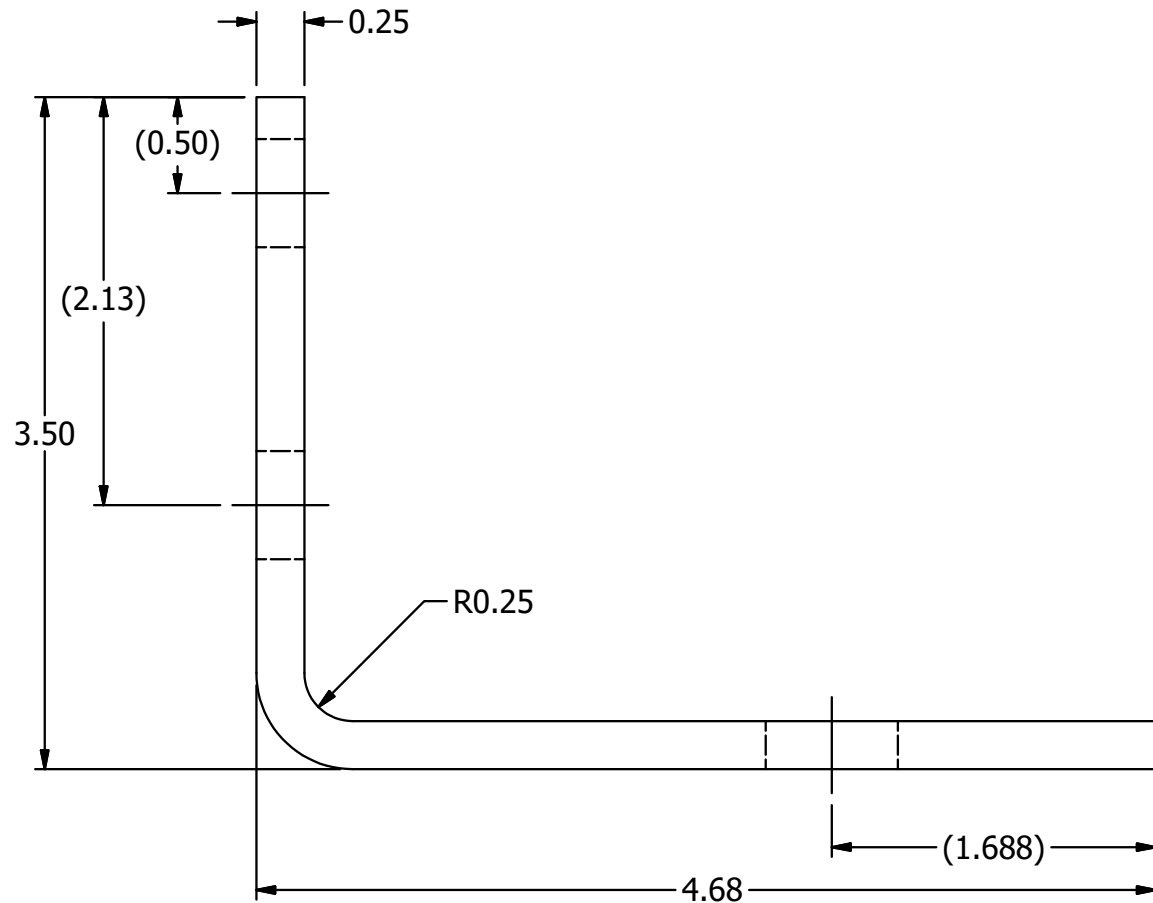

ALL BENDS DOWN 90°, USE 1/4" RADIUS

AMERICAN MOBILE POWER PH: (800) 634-8265 FAX: (765) 948-3403	DRAWING BY: bknight	DESIGN FOR: AMP	FILE NAME: ASK-205-R	
	COMPLETED: 1/24/2008		SHEET: 2 of 2	SHEET SIZE: B

4

3

2

1