

4

3

2

1

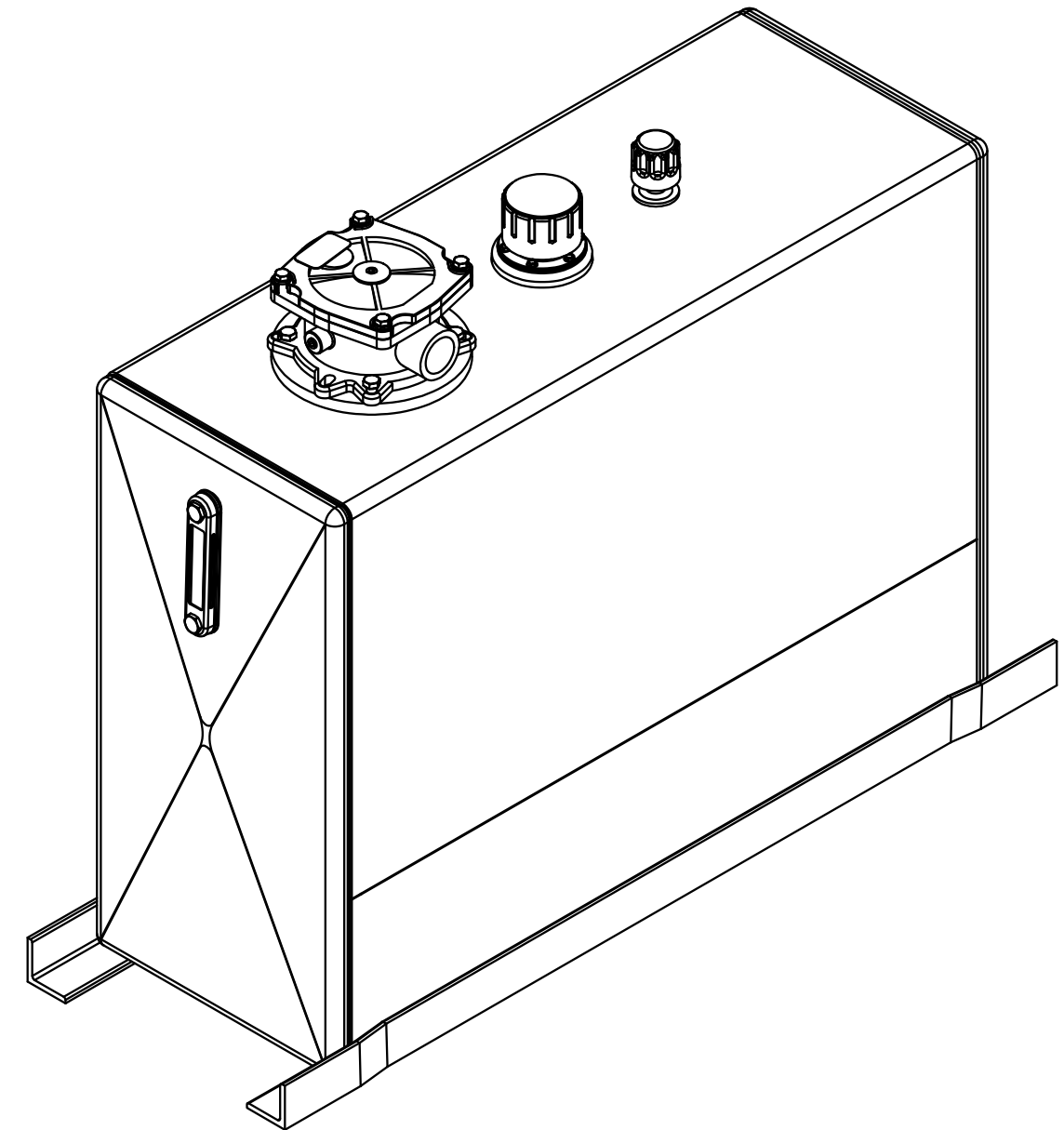
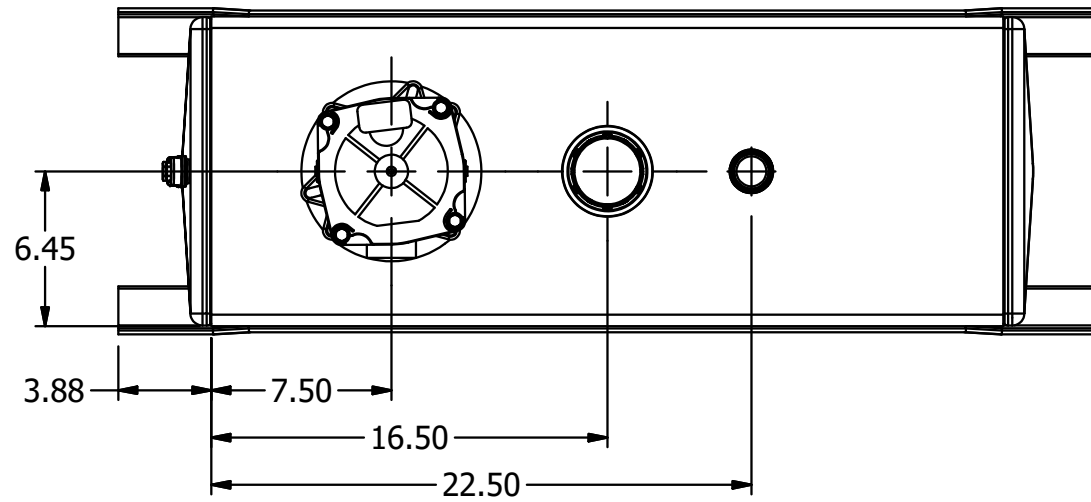

B

B

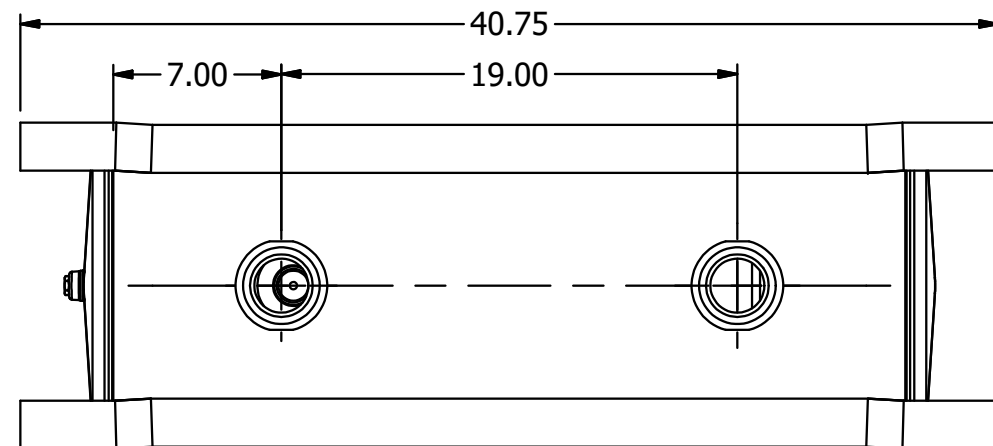
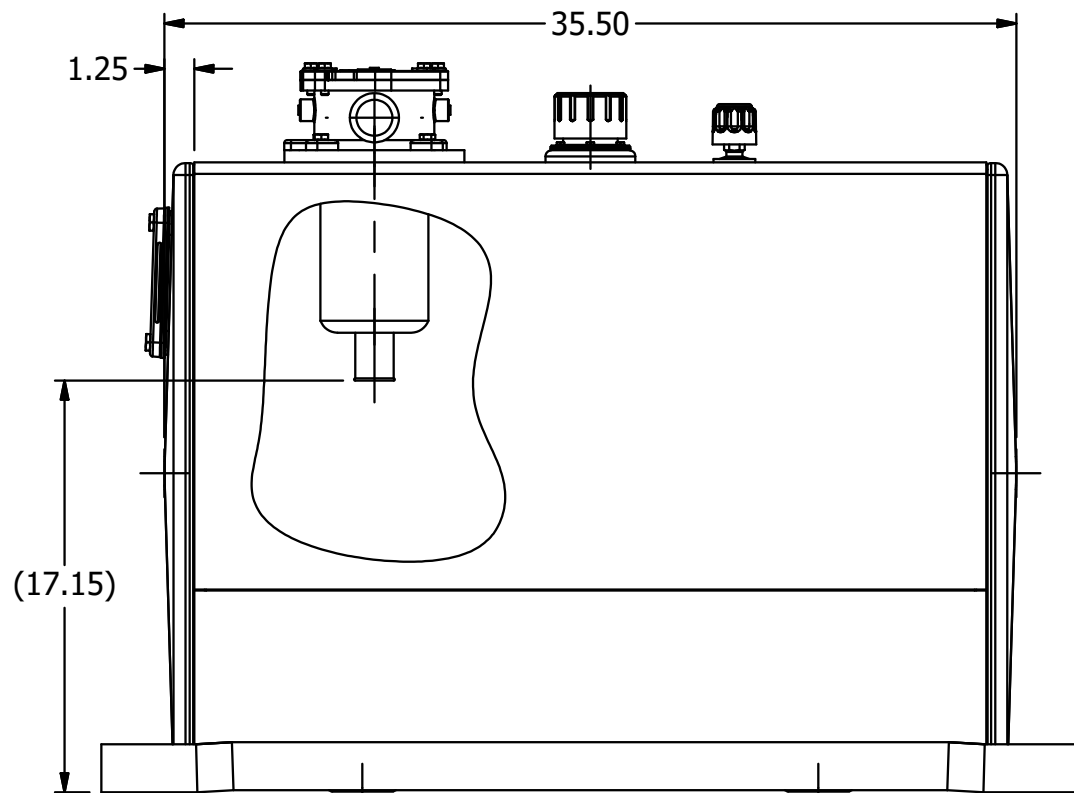
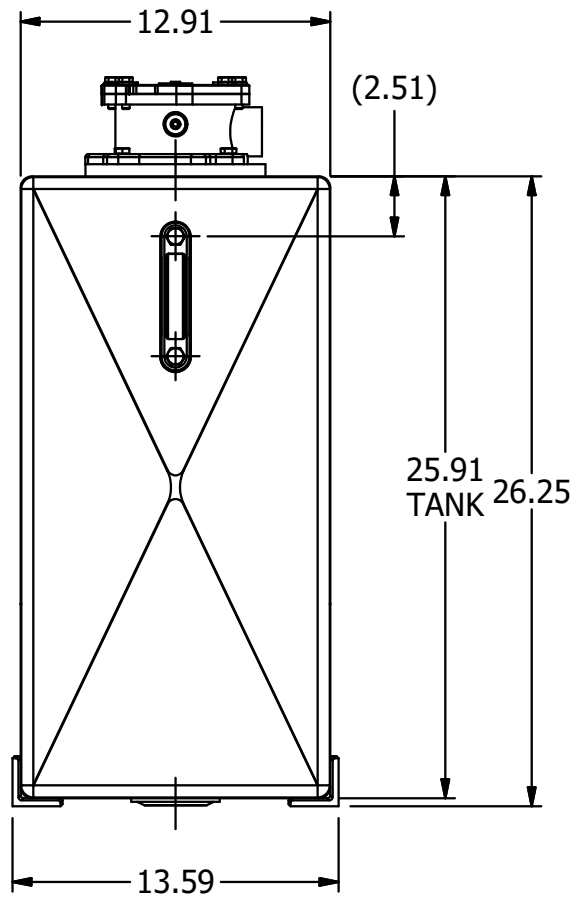

A

A

4

3

2

1

AMERICAN MOBILE POWER PH: (800) 634-8265 FAX: (765) 948-3403	DRAWING BY: BPKNIGHT	DESIGN FOR: AMERICAN MOBILE POWER	FILE NAME: A3000-2STRF	
	COMPLETED: 7/29/2009		SHEET: 2 of 9	SHEET SIZE: B

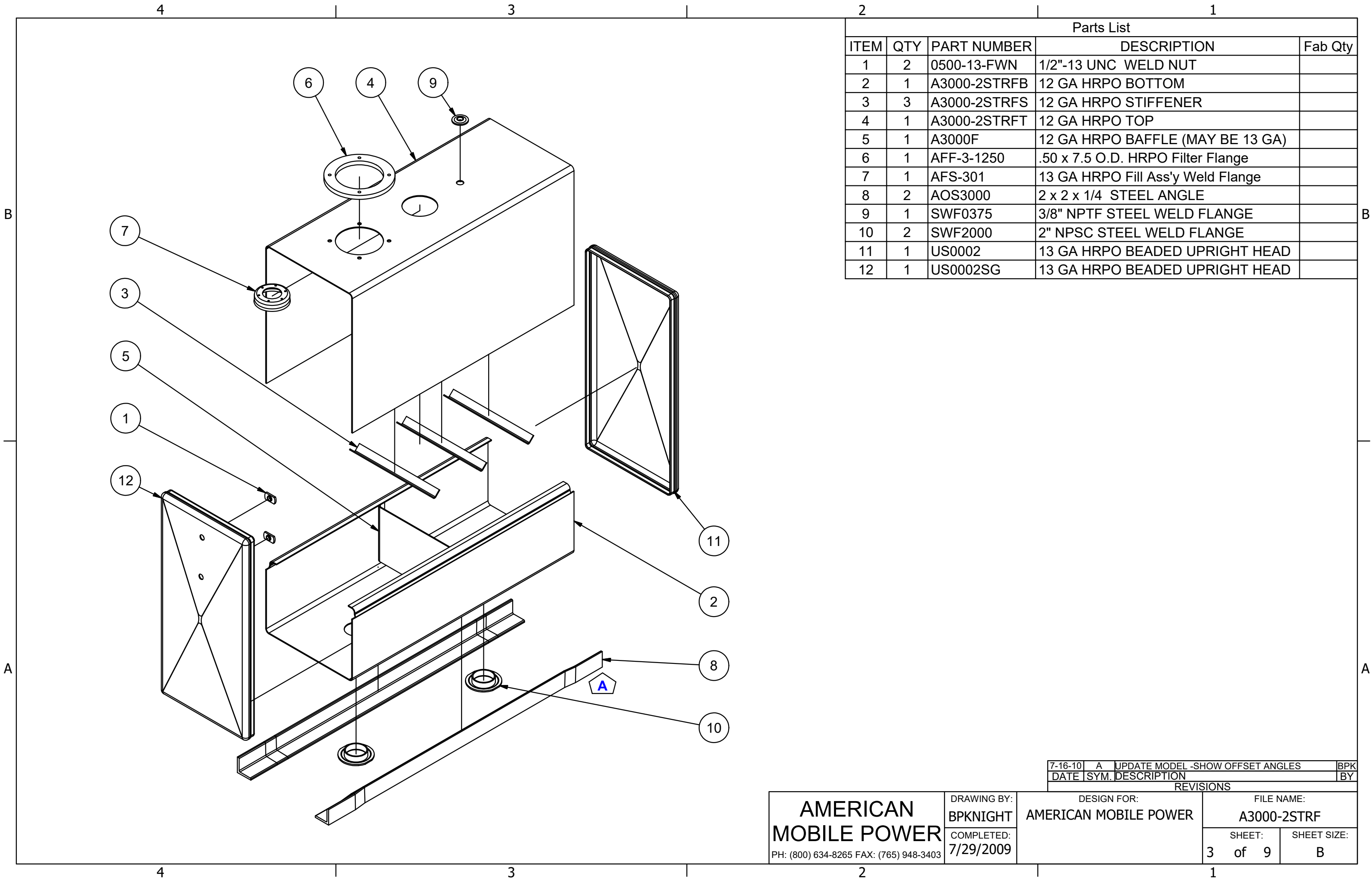

Parts List				
ITEM	QTY	PART NUMBER	DESCRIPTION	Fab Qty
1	2	0500-13-FWN	1/2"-13 UNC WELD NUT	
2	1	A3000-2STRFB	12 GA HRPO BOTTOM	
3	3	A3000-2STRFS	12 GA HRPO STIFFENER	
4	1	A3000-2STRFT	12 GA HRPO TOP	
5	1	A3000F	12 GA HRPO BAFFLE (MAY BE 13 GA)	
6	1	AFF-3-1250	.50 x 7.5 O.D. HRPO Filter Flange	
7	1	AFS-301	13 GA HRPO Fill Ass'y Weld Flange	
8	2	AOS3000	2 x 2 x 1/4 STEEL ANGLE	
9	1	SWF0375	3/8" NPTF STEEL WELD FLANGE	
10	2	SWF2000	2" NPSC STEEL WELD FLANGE	
11	1	US0002	13 GA HRPO BEADED UPRIGHT HEAD	
12	1	US0002SG	13 GA HRPO BEADED UPRIGHT HEAD	

DATE	SYM.	DESCRIPTION	BY
7-16-10	A	UPDATE MODEL -SHOW OFFSET ANGLES	BPK

REVISIONS

AMERICAN MOBILE POWER PH: (800) 634-8265 FAX: (765) 948-3403	DRAWING BY: BPKNIGHT	DESIGN FOR: AMERICAN MOBILE POWER	FILE NAME: A3000-2STRF	
	COMPLETED: 7/29/2009		SHEET: 3 of 9	SHEET SIZE: B