

4

3

2

1

Parts List

ITEM	QTY	PART NUMBER	DESCRIPTION
1	1	57XL-40	40 Micron FILL w/30 Mesh Stainless Strainer
2	1	APP0750-M	3/4" NPT MAG PLUG
3	1	APP1250	1 1/4" NPT SQUARE SOCKET PLUG
4	1	APP2000	2" NPT SQUARE SOCKET PLUG
5	1	N_A3300-RF	NAM WELDMENT ~91.49 lbs
6	1	T-LLG-5	SIGHT/TEMP. GAUGE, 5"

NOTES:

- POWDER COAT BLACK
- APPLY RUST INHIBITOR INSIDE
- PLUG ALL PORTS FOR SHIPMENT

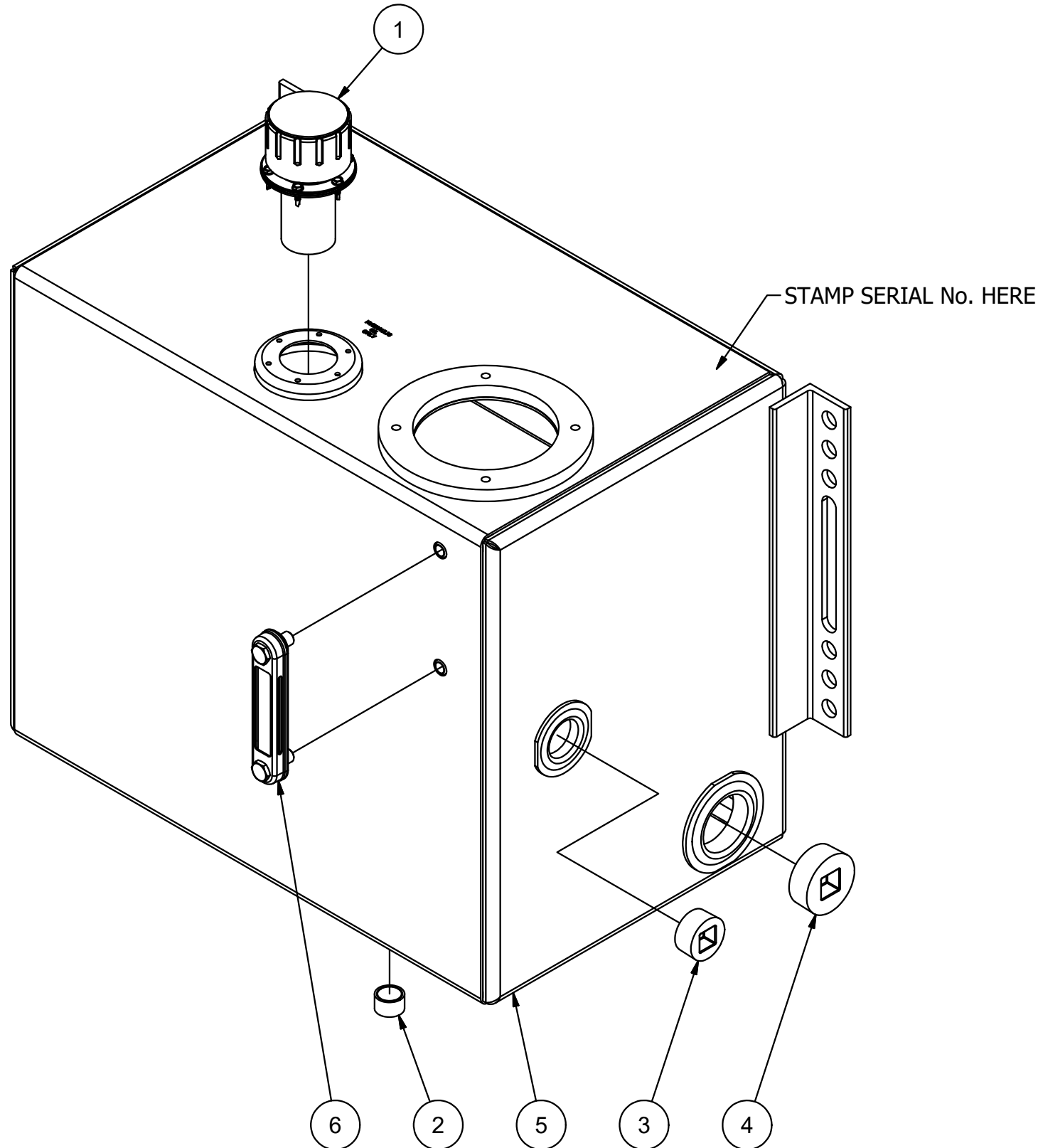

WT: ~93.74 lbs

9-13-18	N/A	ADDED S/N NOTE	BPK
12-27-17	N/A	FILE NAME WAS A3300FR	BPK
DATE	SYM.	DESCRIPTION	BY

REVISIONS

<b>AMERICAN MOBILE POWER</b> PH: (800) 634-8265 FAX: (765) 948-3403	DRAWING BY: BPKNIGHT	DESIGN FOR: AMP	FILE NAME: A3300-RF	
	COMPLETED: 3/12/2012		SHEET: 1 of 8	SHEET SIZE: B

4

3

2

1

4 3 2 1

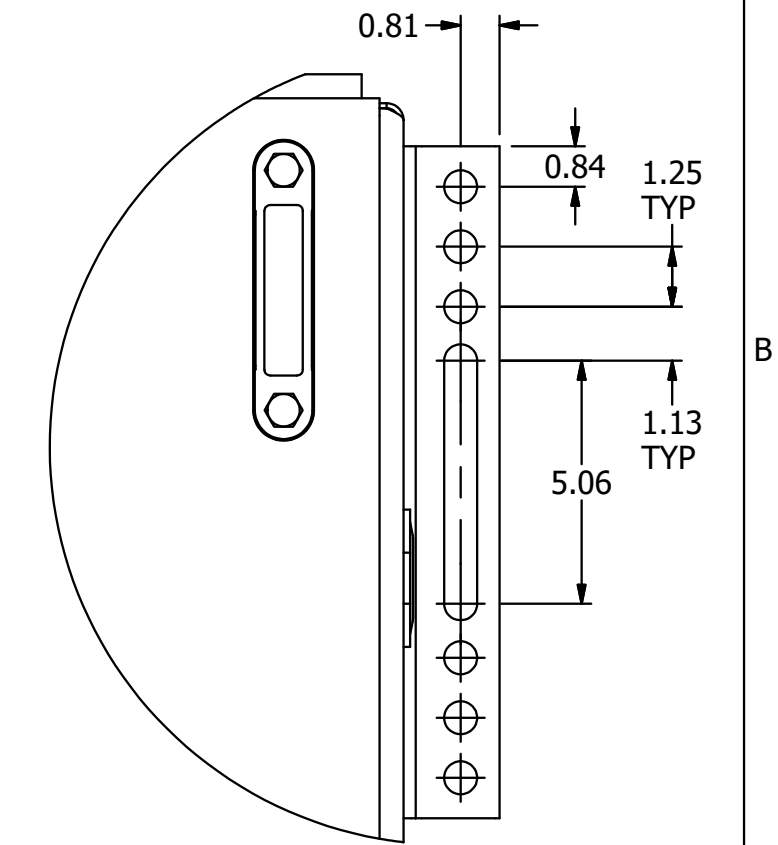
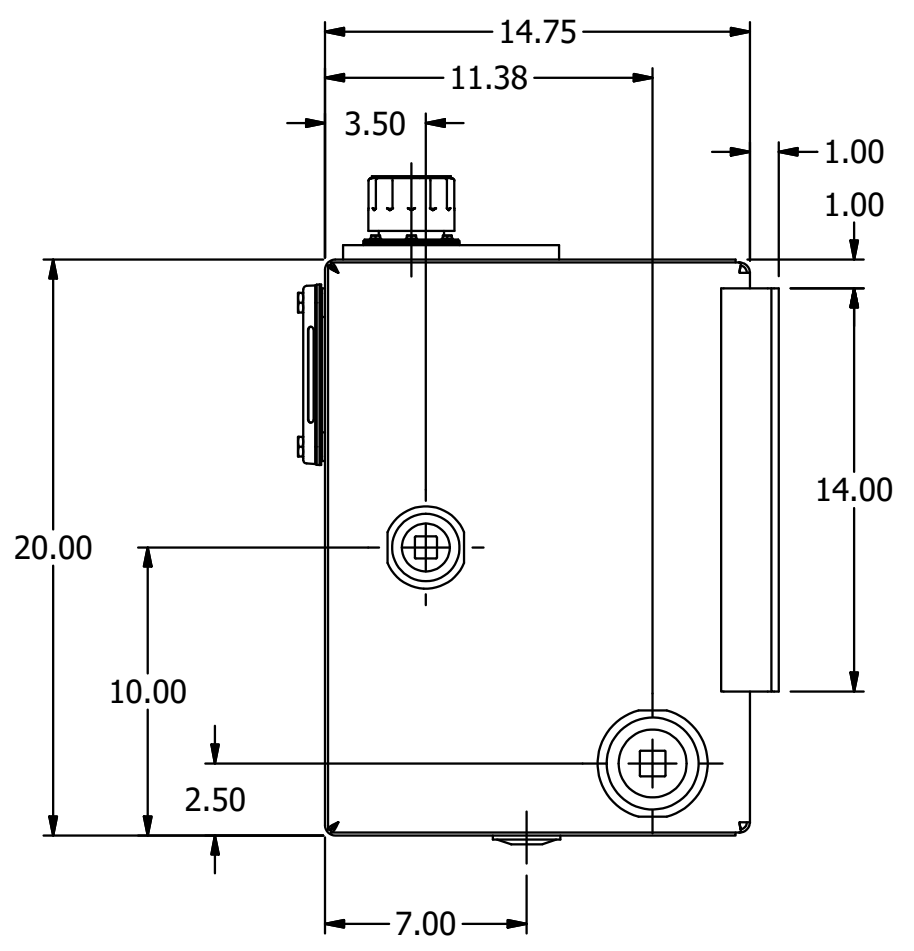
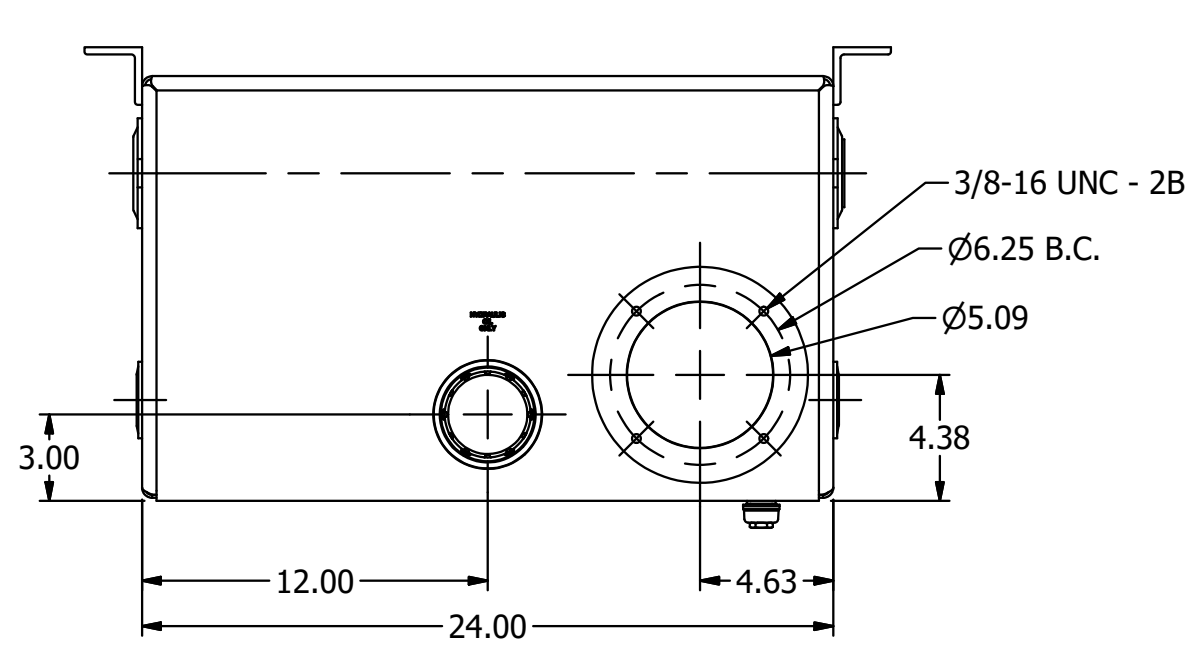

DETAIL A  
 SCALE 1 / 4

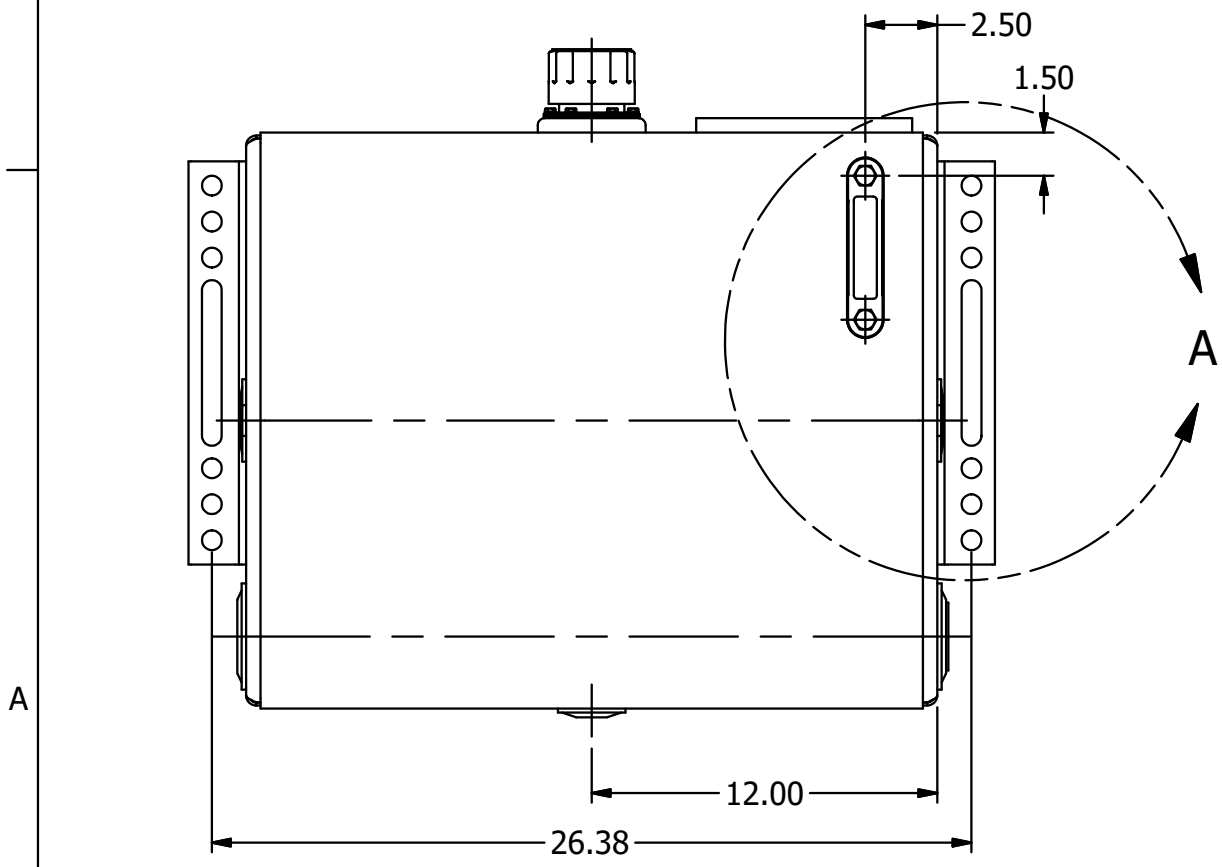

<b>AMERICAN                  MOBILE POWER</b> PH: (800) 634-8265 FAX: (765) 948-3403	DRAWING BY: BPKNIGHT	DESIGN FOR: AMP	FILE NAME: A3300-RF	
	COMPLETED: 3/12/2012		SHEET: 2 of 8	SHEET SIZE: B

4 3 2 1

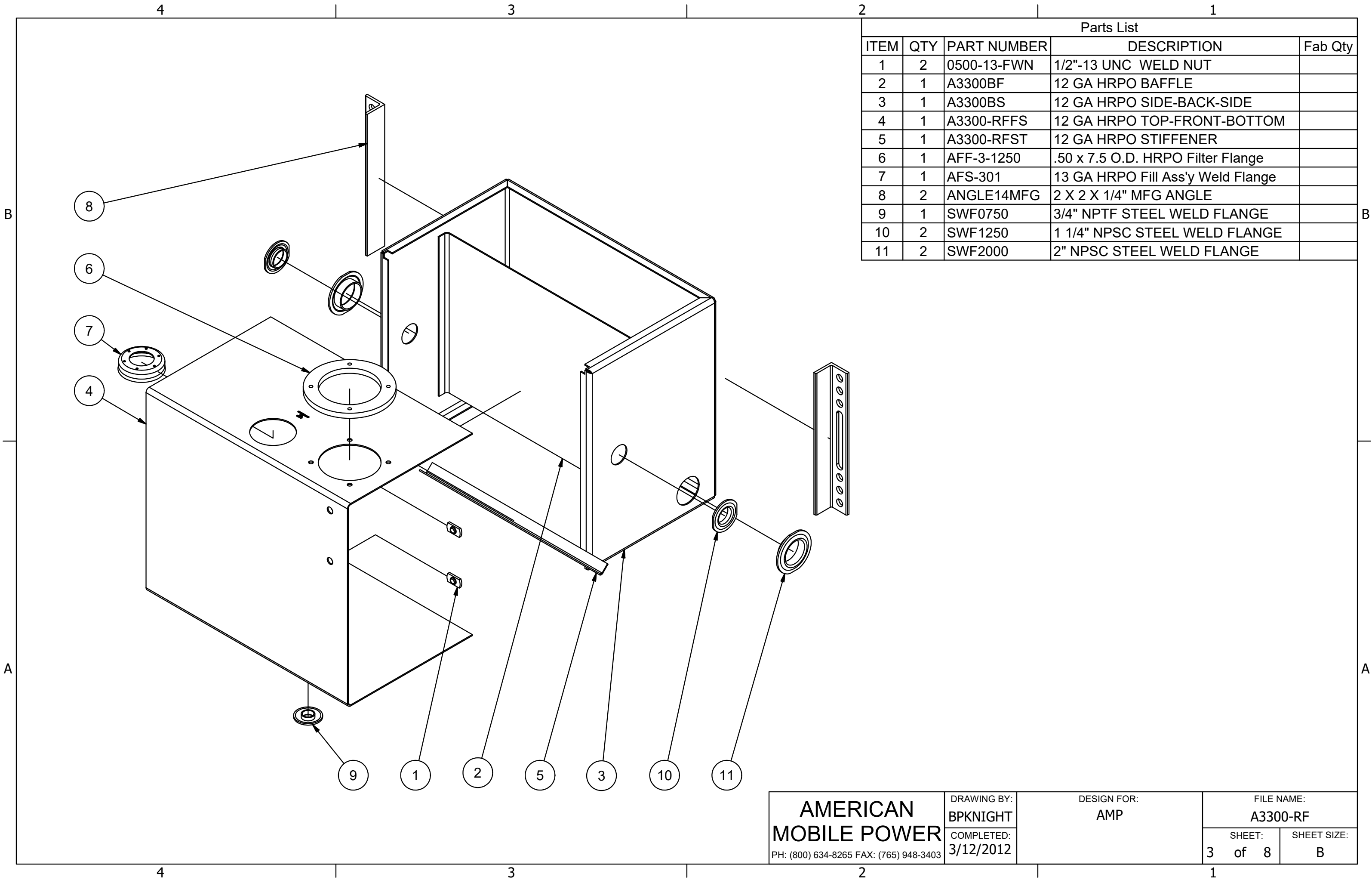

Parts List				
ITEM	QTY	PART NUMBER	DESCRIPTION	Fab Qty
1	2	0500-13-FWN	1/2"-13 UNC WELD NUT	
2	1	A3300BF	12 GA HRPO BAFFLE	
3	1	A3300BS	12 GA HRPO SIDE-BACK-SIDE	
4	1	A3300-RFFS	12 GA HRPO TOP-FRONT-BOTTOM	
5	1	A3300-RFST	12 GA HRPO STIFFENER	
6	1	AFF-3-1250	.50 x 7.5 O.D. HRPO Filter Flange	
7	1	AFS-301	13 GA HRPO Fill Ass'y Weld Flange	
8	2	ANGLE14MFG	2 X 2 X 1/4" MFG ANGLE	
9	1	SWF0750	3/4" NPTF STEEL WELD FLANGE	
10	2	SWF1250	1 1/4" NPSC STEEL WELD FLANGE	
11	2	SWF2000	2" NPSC STEEL WELD FLANGE	

<b>AMERICAN MOBILE POWER</b> <small>PH: (800) 634-8265 FAX: (765) 948-3403</small>	DRAWING BY: BPKNIGHT	DESIGN FOR: <b>AMP</b>	FILE NAME: A3300-RF	
	COMPLETED: 3/12/2012		SHEET: 3 of 8	SHEET SIZE: B