

4

3

2

1

Parts List

ITEM	QTY	PART NUMBER	DESCRIPTION
1	4	13309	5/8-11 UNC x 1.5 Hex Cap Screw
2	8	33016	1 3/4 x 11/16 x 1/8 Thk Steel Plain Washer
3	4	37036	5/8 Std NC Nylock Nut
4	1	57XL-40	40 Micron FILL w/30 Mesh Stainless Strainer
5	1	AFC-507	FILTER PORT COVER 6.25 DIA. B.C.
6	2	AMA-14MFG-2L	2 x 2 x 1/4" MFG ANGLE, 2 Legs Punched
7	1	APP0750-M	3/4" NPT MAG PLUG
8	1	N_A338SL	22.75W21H19D NAM WELDMENT ~128 lbs
9	1	T-LLG-5	SIGHT/TEMP. GAUGE, 5"

* ON ORDER ONLY: LIT-1250-10P IN-TANK RETURN FILTER

- NOTES:
 -POWDER COAT BLACK
 -APPLY RUST INHIBITOR INSIDE
 -PLUG ALL PORTS FOR SHIPMENT

ANGLES AND FASTENERS SHIP LOOSE

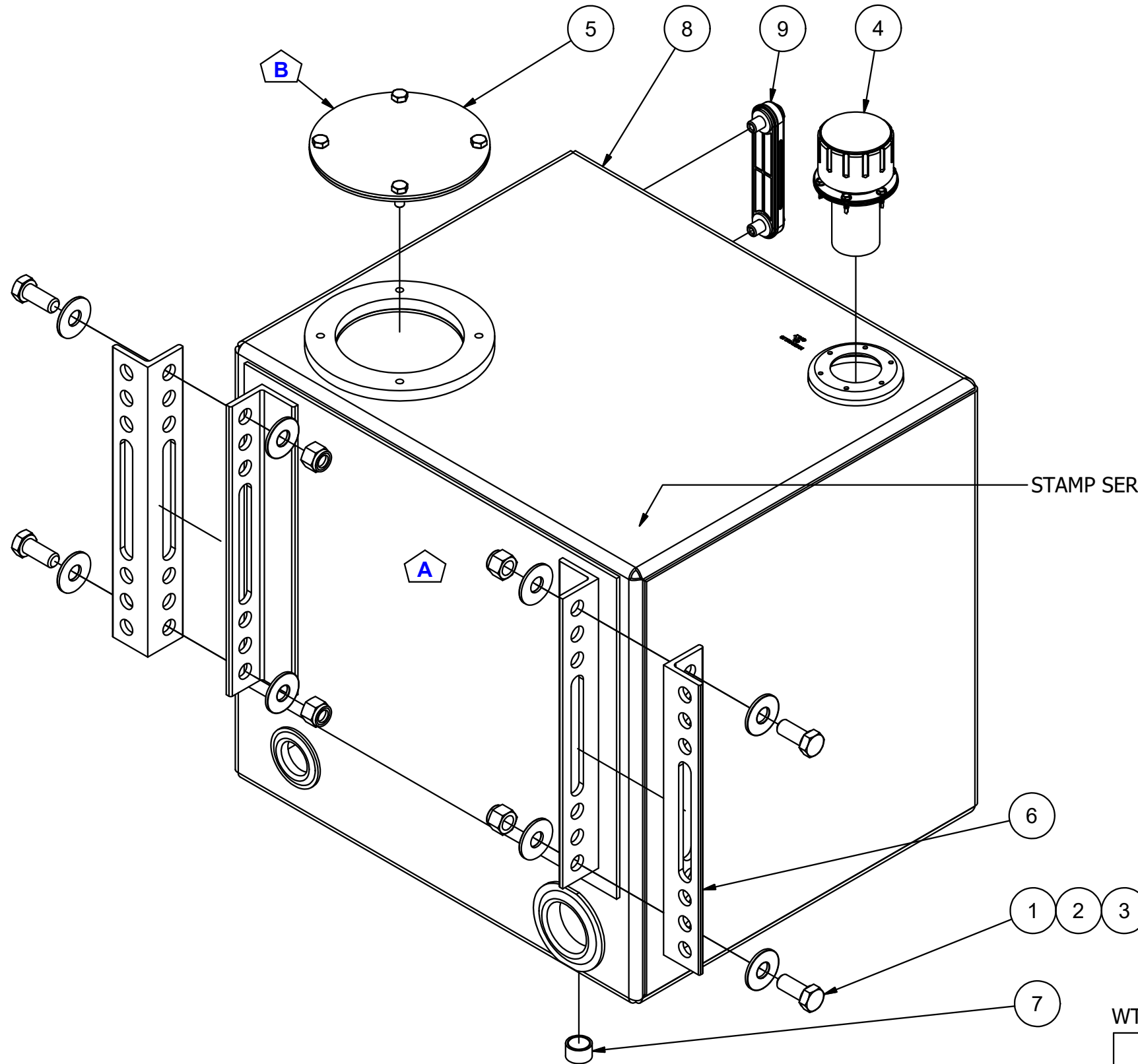
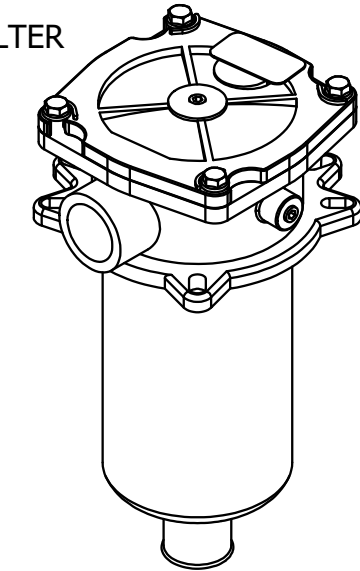

STAMP SERIAL No. HERE

WT: ~137.97 lbs

DATE	SYM.	DESCRIPTION	BY
9-13-18	N/A	ADDED S/N NOTE	BPK
11-24-15	B	DEL. OPTIONAL FILTER; SHOW COVER	BPK
11-4-13	A	ADD SUPPORT PLATE; REV. BAFFLE	BPK

AMERICAN MOBILE POWER PH: (800) 634-8265 FAX: (765) 948-3403	DRAWING BY: BPKNIGHT	DESIGN FOR: AMP	FILE NAME: A338SL	
	COMPLETED: 5/5/2009		SHEET: 1 of 8	SHEET SIZE: B

4

3

2

1

B

B

A

A

4

3

2

1

REVISIONS

DATE	SYM.	DESCRIPTION	BY
11-4-13	A	ADD SUPPORT PLATE; REV. BAFFLE	BPBK
11-24-15	B	DEL. OPTIONAL FILTER; SHOW COVER	BPBK

HYDRAULIC OIL ONLY

DETAIL A

3/8"-16 x4
Ø6.25 B.C.

B

B

A

A

Ø0.688

**AMERICAN
MOBILE POWER**

PH: (800) 634-8265 FAX: (765) 948-3403

DRAWING BY:
BPKNIGHT
COMPLETED:
5/5/2009

DESIGN FOR:
AMP

FILE NAME:
A338SL

SHEET:
2 of 8

SHEET SIZE:
B

4

3

2

1

4

3

2

1

Parts List

ITEM	QTY	PART NUMBER	DESCRIPTION	Fab Qty
1	2	0500-13-FWN	1/2"-13 UNC WELD NUT	
2	1	A338SLBB	10 GA HRPO BACK SHEET	
3	1	A338SLBF	12 GA HRPO BAFFLE	
4	1	A338SLFS	12 GA HRPO SIDE-FRONT-SIDE	
5	1	A338SLPB	7 GA HRPO SUPPORT PLATE	
6	1	AFF-3-1250	.50 x 7.5 O.D. HRPO Filter Flange	
7	1	AFS-301	13 GA HRPO Fill Ass'y Weld Flange	
8	2	ANGLE14MFG	2 X 2 X 1/4" MFG ANGLE	
9	1	SWF0750	3/4" NPTF STEEL WELD FLANGE	
10	1	SWF1250-R	1 1/4" NPSC STEEL WELD FLANGE	
11	1	SWF2000	2" NPSC STEEL WELD FLANGE	

B

B

A

A

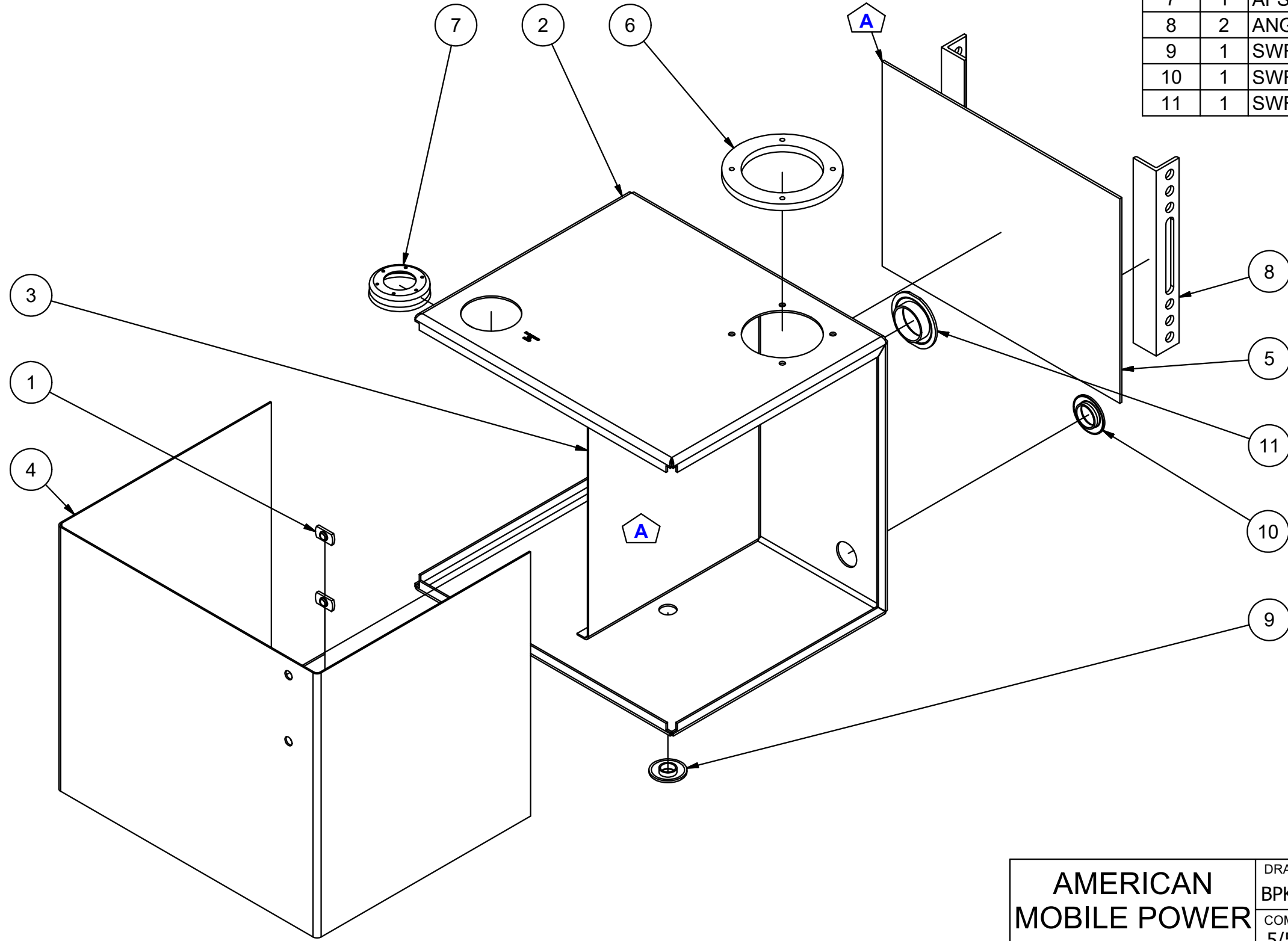

DATE	SYM.	DESCRIPTION	BY
11-4-13	A	ADD SUPPORT PLATE; REV. BAFFLE	BPK

REVISIONS

AMERICAN MOBILE POWER PH: (800) 634-8265 FAX: (765) 948-3403	DRAWING BY: BPKNIGHT	DESIGN FOR: AMP	FILE NAME: A338SL	
	COMPLETED: 5/5/2009		SHEET: 3 of 8	SHEET SIZE: B

4

3

2

1